

PROTECTED



# Specification – MV Composite Cross-arms

Standard Number: HPC-8MJ-07-0002-2018

Issue Date: 7<sup>th</sup> February 2023

Document Number: DM# 10067687

Print Date: 7/02/2023

Uncontrolled document when downloaded. Refer to Horizon Power's website for most current version.

© Horizon Power Corporation 2017

Document Control		
<b>Author</b>	<b>Name:</b> Mondli Moyo <b>Position:</b> Engineer	
<b>Reviewed By</b>	<b>Name:</b> Paul Savig <b>Position:</b> Senior Standards Engineer	
<b>Endorsed By</b>	<b>Name:</b> Johnathan Choi <b>Position:</b> Standards and Plant Manager	
<b>Approved By</b>	<b>Name:</b> Victor Cheng <b>Position:</b> Manager Engineering and Project Services	
<b>Date Created/Last Updated</b>	7 February 2022	
<b>Review Frequency **</b>	3 years	
<b>Next Review Date **</b>	7 February 2025	

\* Shall be the Process Owner and is the person assigned authority and responsibility for managing the whole process, end-to-end, which may extend across more than one division and/or functions, in order to deliver agreed business results.

\*\* Frequency period is dependent upon circumstances– maximum is 5 years from last issue, review, or revision whichever is the latest. If left blank, the default shall be 1 year unless otherwise specified.

Revision Control		
Revision	Date	Description
1	07/02/2023	Reformatted, reviewed and aligned to latest standards
0	01/05/2018	Original Document Issue

STAKEHOLDERS	
<i>The following positions shall be consulted if an update or review is required:</i>	
Manager Engineering & Project Services	Regional Asset Managers
Manager Asset Management Services	Manager Health and Safety

**TABLE OF CONTENTS**

<b>1</b>	<b>Scope .....</b>	<b>5</b>
<b>2</b>	<b>Normative References .....</b>	<b>5</b>
2.1	Standards .....	5
2.1.1	Horizon Power Standards .....	5
2.1.2	Australian Standards .....	5
2.1.3	International Standards .....	5
2.1.4	Other References .....	5
2.2	Definitions and Abbreviations .....	6
<b>3</b>	<b>Requirements .....</b>	<b>7</b>
3.1	General .....	7
3.2	Dimensions .....	7
3.3	Loading Points & End Caps .....	7
3.4	Design Life .....	8
3.5	Strength .....	8
3.5.1	Applicable Loads .....	8
3.5.2	Serviceability .....	9
3.6	Electrical Properties .....	9
3.7	Durability .....	9
3.8	Maintenance .....	9
3.9	Environmental Parameters .....	9
3.10	Cross-arm Coating .....	10
3.11	Compatibility and Interchangeability .....	10
3.12	Weight .....	10
<b>4</b>	<b>Packaging Requirements .....</b>	<b>10</b>
<b>5</b>	<b>Storage .....</b>	<b>11</b>
<b>6</b>	<b>Reliability .....</b>	<b>11</b>
<b>7</b>	<b>Safety .....</b>	<b>11</b>
<b>8</b>	<b>Environmental Considerations .....</b>	<b>11</b>
<b>9</b>	<b>Tests .....</b>	<b>11</b>
9.1	Test Requirements .....	11
9.2	Test Certificates .....	12
9.3	Mechanical Tests .....	12

9.4	Electrical Tests .....	12
9.4.1	Tracking and Erosion Test .....	12
9.5	Durability Tests .....	12
9.5.1	Aging (UV with Moisture) .....	12
9.5.2	Rainfall and High Humidity .....	12
9.5.3	Resistance to Fire Damage .....	13
9.5.4	Pollution .....	13
9.6	Batch Tests .....	13
<b>10</b>	<b>Documentation and Samples.....</b>	<b>13</b>
10.1	Documentation to be provided with Proposals .....	13
10.2	Service History .....	14
10.3	Training Materials .....	14
10.4	Samples .....	14
	APPENDIX A Revision Information .....	15
	APPENDIX B : Quality Assurance (to be completed by stores) .....	16
	APPENDIX C Schedules A &B.....	18
	APPENDIX D Compliance Document .....	19
	APPENDIX E Departures from Technical Specification .....	21
	APPENDIX F Indicative Drawing of the Composite Cross-arm .....	22
	APPENDIX G Intermediate Insulator Pin .....	23
	APPENDIX H Strain/Termination Insulator Eye-Bolt.....	24
	APPENDIX I 'T' Bracket .....	25
	APPENDIX J 'Raiser' Brackets .....	26

## 1 SCOPE

This Specification details the requirements for manufacture, supply, testing and delivery of Composite Fibre cross-arms for use on overhead electricity distribution systems in an exposed environment. Horizon Power uses composite cross-arms to support medium voltage (36 kV) bare aerial conductors. They are required to have the following properties which are either equivalent to or more advantageous to the traditional timber cross-arm:

- strength
- durability; and
- electrical properties

This Specification identifies the performance parameters, test requirements and information provided by the Preferred Vendor.

## 2 NORMATIVE REFERENCES

### 2.1 Standards

#### 2.1.1 Horizon Power Standards

- [1]. *Horizon Power Environmental Conditions HPC-9EJ-01-0001-2013*, Horizon Power, DM# 2302921, available at <http://horizonpower.com.au/contractors-suppliers/contractors/manuals-and-standards/> under the 'Standards' heading.

#### 2.1.2 Australian Standards

The following standards are available at <http://www.saiglobal.com>.

- [2]. *AS 1199.1, Sampling procedures for inspection by attributes - Sampling schemes indexed by acceptance quality limit (AQL) for lot-by-lot inspection*, Standards Australia, 2003.
- [3]. *AS/NZS 7000, Overhead Line Design – Detailed Procedures*, Standards Australia, 2016.

#### 2.1.3 International Standards

The following standards are available at <http://www.saiglobal.com>

- [4]. *IEC 60587, Electrical insulating materials used under severe ambient conditions - Test methods for evaluating resistance to tracking and erosion*, International Electrotechnical Committee, 2022.
- [5]. *IEC 60695, Fire hazard testing - Part 2-12: Glowing/hot-wire based test methods - Glow-wire flammability index (GWFI) test method for materials*, International Electrotechnical Committee, 2021.
- [6]. *IEC 60812, Analysis techniques for system reliability—Procedure for failure mode and effects analysis (FMEA)*, International Electrotechnical Committee, 2006

#### 2.1.4 Other References

The following standards are available at <http://www.saiglobal.com> unless otherwise stated.

## PROTECTED

- [7]. ACI 318-19, Building Code Requirements for Structural Concrete. American Concrete Institute, 2022, available at <https://www.concrete.org/>
- [8]. *ASTM D2303-20e1, Standard Test Methods for Liquid-Contaminant, Inclined-Plane Tracking and Erosion of Insulating Materials*, American Society for Testing and Materials.
- [9]. *ASTM G154-16, Standard Practice for Operating Fluorescent Ultraviolet (UV) Lamp Apparatus for Exposure of Nonmetallic Materials*, American Society for Testing and Materials
- [10]. *ENA DOC 012, Cross-arm Supply and Performance Specification*, Energy Networks Association, 2006, available at <https://www.energynetworks.com.au/guidelines/>
- [11]. *JIS K 7015, Pultruded Fibre-reinforced Plastics*, Japanese Standards Association, 2013.
- [12]. *Structural Design of Polymer Composites, Eurocomp Design Code and Background Document, 2019*, available at <https://www.routledge.com/Structural-Design-of-Polymer-Composites-Eurocomp-Design-Code-and-Background/Clarke/p/book/9780367865078>

## 2.2 Definitions and Abbreviations

For the purposes of this Specification, the following descriptions shall apply:

- Intermediate Connection Cross-arm
- Termination/Strain Connection Cross-arm

The cross-arm arrangements at both intermediate and termination/strain locations are shown in Figure 2-1 and Figure 2-2. The cross-arm is attached to the pole with a pair of M16 king bolts and a 'T' bracket. Refer to the 'T' Bracket drawing presented in APPENDIX I .

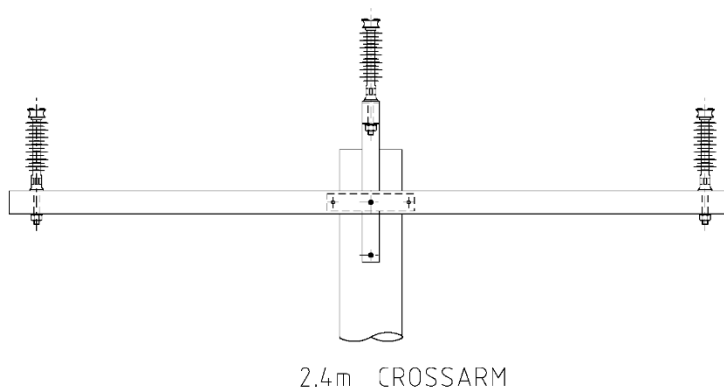

Figure 2-1: Typical arrangement at intermediate locations

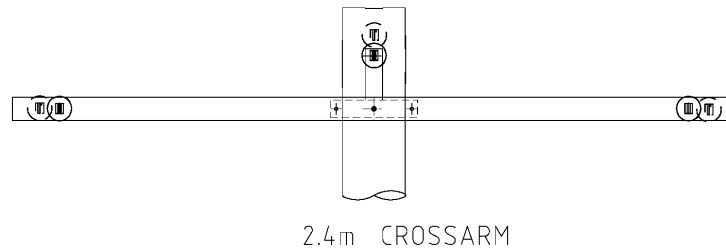

Figure 2-2: Typical arrangement at termination/strain locations

In addition, the following general definitions are listed below in alphabetical order:

**Equipment:** Cross-arm

### 3 REQUIREMENTS

#### 3.1 General

Performance criteria shall be as per ENA DOC 012 [10] with the exceptions noted below. Where ENA DOC 012 [10] refers to ESAA C(b) 1, this reference should be replaced with AS/NZS 7000:2016 [3].

#### 3.2 Dimensions

The manufacturing tolerance shall be as per Pultruded Fibre-reinforced Plastics JIS K 7015 [11].

Critical dimensions of the *Equipment* are specified in APPENDIX F . Tenderers shall propose suitable width, thickness and height of the *Equipment* to meet the load requirements. The cross-arm shall have bolt hole sizes and critical dimensions compatible with the current hardware including;

- a) Post Insulator bolt dimension shown in APPENDIX G
- b) Strain/Termination eye-bolt dimension shown in APPENDIX H
- c) Mounting bracket dimension shown in APPENDIX I

#### 3.3 Loading Points & End Caps

Any fillers, inserts or devices used to reinforce the strength of the *Equipment* at loading points shall not protrude beyond the outside surface of the *Equipment*.

Composite cross-arms shall have the ends capped by a non-conductive material that is impact resistant, secure, permanently fixed, and will not degrade during the service life of the *Equipment*.

All fillers, inserts and end caps shall be such that they prevent water ingress into the cross-arm.

**3.4 Design Life**

The design life should be at least 50 years.

Preferred Vendors must state the expected design service life of the *Equipment* and submit their proposal/test report to validate the minimum design life.

**3.5 Strength**

**3.5.1 Applicable Loads**

The *Equipment* must be able to withstand the dead loads, tensile loads, and wind loads under maximum wind condition presented in Table 3-1. In addition, the interaction of bending and axial (compression/tension) shall be verified as per Eurocomp Design Code [12] or equivalent Standard (refer to the Technical Schedule requirements). The applicable material strength reduction factor ( $\phi=0.75$ ) shall be considered in the *Equipment* design, as per ACI 318-19 [7].

The Preferred Vendor must submit the test result copies and the applicable calculations to confirm that the offered *Equipment* is fit for purpose.

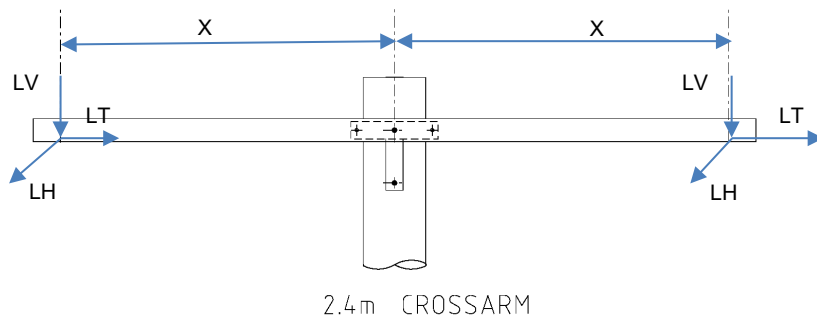

Figure 3 1: Cross-arm Action Requirements

Table 3-1: Cross-arm Design Requirements

Load Description (Refer to Figure 3-1)	Intermediate Arrangement	Strain/Termination Arrangement
LV (kN)	3.2	0.6
LT (kN)	4.5	1.8
LH (kN)	4.2	22.4
Distance between phase connection and centre point of the cross-arm (X)	1.05 m (2.4 m cross-arm) 1.5 m (3 m cross-arm)	
Crush Resistance Torque with Washer for M16 bolt ( $\phi R_n$ )	100.0 Nm	
Connection capacity at M16 connection ( $\phi R_n$ )	40 kN	



PROTECTED

Load Description (Refer to Figure 3-1)	Intermediate Arrangement	Strain/Termination Arrangement
Torsion Capacity ( $\phi R_n$ )	3.0 kNm	

(For **Horizon Power use only** - Calculation details for the above table can be found in DM# 39355246.)

**3.5.2 Serviceability**

As per Section 4.2.7 of ENA DOC 012 [10], the vertical deflection of the *Equipment* due to dead load must be limited to a maximum of 5% of bendable length.

For termination arrangements, conductors are longitudinally connected and Vendors are required to demonstrate deflection is within the 5% limit in the longitudinal direction.

**3.6 Electrical Properties**

As the composite cross-arms are electrically insulating they must meet the minimum requirements in accordance with ENA DOC 012 [10] Clause 4.3.

The electrical properties shall be maintained in the environment specified in Section 3.9, for the design life of the *Equipment* as per Section 3.4.

**3.7 Durability**

The *Equipment* must meet the durability requirements of ENA DOC 012 [10] for the design life specified in Section 3.4. The following durability performance is required:

- a) Resistance to attack by natural agents-both physical and biological;
- b) Form and dimensional stability;
- c) Performance of adhesives and mechanical fastening systems;
- d) Resistance to fire damage;
- e) The *Equipment* shall not delaminate over the design life; and
- f) Resistance to any forms of deterioration that would prevent the *Equipment* from performing to its strength requirements in Section 3.5 for the *Equipment* design life specified in Section 3.4.

**3.8 Maintenance**

The *Equipment* and any integrated fittings should preferably be maintenance free for the *Equipment* design life specified in Section 3.4. Where this is not compliant the Vendor must advise the required maintenance regime.

**3.9 Environmental Parameters**

The *Equipment* to be supplied under this specification shall be suitable for a hostile outdoor environment as per the *Horizon Power Environmental Conditions* [1]. This includes being resistant to tracking and dry-band arcing caused by deposits of salt or pollutants.

## PROTECTED

The *Equipment* Vendors must provide an end-of-life strategy for their products. Ideally the product will be reused or recycled, with disposal being the least attractive option.

### 3.10 Cross-arm Coating

The cross-arm coating shall not be painted on, although repair of damaged coating may consist of a painted solution. Vendors to provide a repair option as an offering for the duration of this tender.

### 3.11 Compatibility and Interchangeability

The *Equipment* must be compatible and interchangeable with the current cross-arms and hardware. Refer to Appendices for the current cross-arm and hardware drawings.

### 3.12 Weight

Refer to ENA DOC 012 [10] Clause 4.9.

## 4 PACKAGING REQUIREMENTS

The *Equipment* shall be suitably packaged, such that it is “fit for use” at any location in Horizon Power’s operational area and specifically include all accessories needed. Packaging shall be capable of preventing damage whilst in storage and during transit to remote locations. The Vendor is required to nominate standard pack quantities and standard packs shall be clearly marked with the following information:

- 1) Manufacturer’s name;
- 2) Manufacturer’s part reference number;
- 3) Batch Number;
- 4) Horizon Power Order Number;
- 5) Horizon Power Stock Number;
- 6) *Equipment* description (voltage rating); and
- 7) Package weight.

Very strong consideration shall be given to appropriate packaging provided with any *Equipment* offered under this specification, with respects to satisfying the “fit for use” criteria mentioned above.

The combined height of the pallet and *Equipment* of a standard pack shall not exceed 1,050 mm.

Each shipment shall be provided with box labels stating the part, stock and contract number as well as the routine test reports.

Each package is to have an identifying bar code and number which identifies as a minimum the:

- Manufacturers part number;
- Manufacturer;
- Factory of manufacture; and
- Month and year of manufacture.

The bar code should be code 128 and can be applied either by spray or on a plastic tag. The bar code and number does not have to be indelible beyond installation.

**Note:** The Vendor is required to identify the cost of providing bar coding as specified in this Section separately from the other cost requirements of this specification.

## 5 STORAGE

The *Equipment* shall be capable of being stored without deterioration within the temperature range of -10 °C to +45 °C for no less than 24 months.

## 6 RELIABILITY

Vendors shall provide information on the reliability of the *Equipment* and the performance of the materials offered over an operational life defined in Section 3.4.

Information provided shall evidence the claimed reliability and performance for the *Equipment* offered, including information on Failure Mode and Effect Analysis, carried out in accordance with IEC 60812 [6].

Vendors may offer their standard *Equipment* but any variation to the foregoing standards must be clearly stated in writing at the time of the proposal. The products offered in the standing offer should be equal to or better in quality and performance than the existing items as listed under this Specification.

## 7 SAFETY

Material Safety Data Sheets (MSDS) applicable for each different *Equipment* or chemical ingredient in the *Equipment* which is considered harmful to personnel or environment in any manner, shall be supplied with the Proposal.

## 8 ENVIRONMENTAL CONSIDERATIONS

Vendors are required to provide information on the environmental soundness of the design and the materials used in the manufacture of the items offered. Vendors shall provide a detailed outline of the steps that have been put in place to fulfil any obligations that may be required pursuant to the *Waste Avoidance and Resource Recovery Act 2001* and any amendments. In particular:

- a) Management of waste reduction;
- b) The use of re-usable packing; and
- c) Extended producer responsibility for the safe disposal of materials at the end of their life.

## 9 TESTS

### 9.1 Test Requirements

The Vendor shall prior to first delivery, complete the design, type, routine, sample and special tests and inspections as required by the relevant standards.

## PROTECTED

The passing of such tests does not prejudice the right of Horizon Power to reject the *Equipment* or fitting if it does not comply with this Specification when installed.

**Note:** A condition of acceptance on imported products shall be to perform landing routine and sample tests completed in Australia on each batch imported. In these cases each batch must obtain a passed landing test in order that the batch acceptance will be reflected on an acceptance list.

### 9.2 Test Certificates

At the time of submitting the offer on the tender, single copies of test certificates, in English, shall be provided and shall be clearly marked and contain a reference number. If all the required test certificates are not submitted the tender will be rated incomplete and may not be considered.

Electronic copies of type test certificates shall be arranged in the order set out in this Specification and shall be marked clearly with the identifier and description in the contents Section. Any extra test certificates shall be marked with "extra tests" and kept separate from the required test certificates.

All tests required by the relevant standards shall be carried out. Test certificates shall be submitted in electronic format and shall be in Adobe Acrobat (.pdf) format.

### 9.3 Mechanical Tests

Mechanical tests shall be carried in accordance with Clause 5.1 and 5.2 of ENA DOC 012 [10].

### 9.4 Electrical Tests

Electrical tests shall be carried out in accordance with Clause 5.3, 5.4 and 5.5 of ENA DOC 012 [10].

#### 9.4.1 Tracking and Erosion Test

The Tracking and erosion test shall be carried out as per IEC 60587 [4] or ASTM D2303 [8].

### 9.5 Durability Tests

#### 9.5.1 Aging (UV with Moisture)

Vendors shall perform the ASTM G154 [9] test using UVB lamps to generate UV radiation. Specimens shall be exposed to repetitive cycles of light and moisture under controlled environmental conditions preferably in the ratio of 2:1. The entire test duration should be a minimum 5000 hours. After completion of the test, there shall be no degradation in the mechanical strength and material stiffness of the test sample. It is also required that the test sample does not exhibit any significant visual changes.

#### 9.5.2 Rainfall and High Humidity

In the event that there is moisture ingress, the Vendors should be able to substantiate with test results that *Equipment* strength does not fall below the minimum required value and is still able to resist the required loads.

The *Equipment* shall be soaked in water for 24 hours and it should be verified that there is no strength deterioration due to immersion in water.

### 9.5.3 Resistance to Fire Damage

The Vendor shall demonstrate that the *Equipment* have good resistance to pole top fires by passing a glow wire test as per IEC 60695-2-12 [5].

### 9.5.4 Pollution

The crossarm shall be able to withstand the effects of pollution as per the Horizon Power Environmental Conditions HPC-9EJ-01-0001-2013 [1].

The Vendor shall demonstrate with test results that the cross-arm coating remains intact when exposed to the environmental elements. Horizon Power may consider test methodologies proposed by the Vendor for pollution testing.

### 9.6 Batch Tests

Prior to delivery, the Vendor shall submit a sampling test plan in accordance with AS 1199.1 [2] "Sampling procedures for inspection by attributes" and nominate the test facility. The test plan submission shall identify the cross-arms, quantity, and types of tests to be carried out including the frequency of the tests for each batch.

Batch Test Certificates shall be provided with each delivery upon request stating the batch number and that each cross-arm delivered meets all of the requirements in this specification. It is required that the batch test certificates be submitted to Horizon Power through electronic means before material delivery starts. Horizon Power reserves the right to request the original test certificate as and when required.

Other testing programs such as continuous in-line testing may be considered as an alternative to batch testing.

## 10 DOCUMENTATION AND SAMPLES

### 10.1 Documentation to be provided with Proposals

Submitted proposals shall provide all documentation and information as requested in this specification, including any further relevant information on the *Equipment* offered. The proposal must be complete in all respects. Failure to comply may cause the proposal to be considered incomplete and hence informal.

The Vendor shall provide an electronic version of all documents in Adobe Acrobat (.pdf) format containing the information detailed below with their offer:

- Any non-compliance of the Specification shall be detailed in the Technical Deviation schedule.
- All information provided in Technical Requirements shall be in English and measurement units shall be in metric units.
- Material Safety Data Sheets.
- CAD drawings (Micro station preferred DGN format) of all *Equipment* showing all critical dimensions.
- *Equipment* data sheets showing the weight, material type, protective coatings, dimensions, shed profile, total and protected creepage distance, method of fixing and mechanical & electrical properties (Combined Load Charts shall be included).
- Evidence of ability to withstand the service conditions specified including Wind withstand calculations
- Test certificates as detailed in Section 9.

## PROTECTED

- Detailed outline of quality control procedures
- Installation instructions included in the packaging; and
- A copy of the Vendor's current Quality Assurance accreditation and category.

Should the preferred Vendor submit drawings for approval by Horizon Power, this will in no way exonerate it from being responsible for the correct and proper function of the *Equipment*.

### 10.2 Service History

Vendors shall state:

- Other Australian electricity supply authorities who have a service history of the items offered; and
- Contact details of those supply authorities who can verify the service performance claimed.

### 10.3 Training Materials

Training material in the form of drawings, instructions and/or audio visuals must be provided for the items accepted under the offer.

Vendors shall state the availability of training materials which could include but is not limited to the following topics:

- Handling and storage;
- Application (particularly in areas of heavy coastal pollution);
- Installation;
- Maintenance;
- Environmental performance;
- Electrical performance;
- Mechanical performance;
- Disposal at the end of service life; and
- Production process and testing

### 10.4 Samples

Samples of all proposed *Equipment* types are to be provided upon request of Horizon Power as part of the submitted proposals.

PROTECTED

**APPENDIX A REVISION INFORMATION**

(Informative) Horizon Power has endeavoured to provide standards of the highest quality and would appreciate notification of errors or queries.

Each Standard makes use of its own comment sheet which is maintained throughout the life of the standard, which lists all comments made by stakeholders regarding the standard.

A comment sheet found in **DM# 10067761** can be used to record any errors or queries found in or pertaining to this standard. This comment sheet will be referred to each time the standard is updated.

Date	Rev No.	Notes
1/05/2018	0	Initial Document Creation – Based on an existing specification
7/02/2023	1	Updated document to standard template adding requirements for: <ul style="list-style-type: none"><li>• Packaging</li><li>• Storage</li><li>• Reliability</li><li>• Safety</li><li>• Environmental Consideration</li><li>• Documentation and Samples</li></ul> Added requirement for cross-arm coating to not be painted on Added requirement for cross-arm to not delaminate over the design life Added provision for Vendors to provide repair options for damage to the cross-arm coating Added requirement for pollution test

PROTECTED

**APPENDIX B : QUALITY ASSURANCE (TO BE COMPLETED BY STORES)**

<b>DOCUMENT NUMBER</b>		HPC-8MJ-07-0002-2018					<b>QUALITY ASSURANCE</b>		<b>DM NUMBER</b>	
<b>DEVICE DESCRIPTION</b>		<b>LABEL MATERIAL NO.</b>					<b>EQUIPMENT PURCHASE</b>		<b>ASSET OWNER</b>	
		<b>ASSET ID/ STOCK NO</b>								
<b>MANUFACTURER</b>				<b>DIMENSION</b>						
<b>ITEM</b>	<b>OPERATION/EQUIPMENT/FACILITY</b>			<b>DOCUMENT REF.</b>	<b>WHO CHECKS</b>	<b>INITIAL</b>	<b>DATE/ TIME</b>	<b>QUALITY ASSURANCE CRITERIA</b>	<b>PASS Y/N</b>	<b>COMMENTS</b>
1										
1.1	Name of Manufacturer							*****		
1.2	Week & Year of Manufacture							*****		
1.3	Horizon Power Order Number							*****		
1.4	Horizon Power Stock Number							*****		
1.5	Size (length x height x width)							*****		
1.6	Weight							*****		
1.7	Batch Number							*****		
1.8	Physical Appearance							*****		
1.9	Pallet Quantity							*****		
1.10	Pallet Weight							*****		



PROTECTED

ITEM	OPERATION/EQUIPMENT/FACILITY	DOCUMENT REF.	WHO CHECKS	INITIAL	DATE/TIME	QUALITY ASSURANCE CRITERIA	PASS Y/N	COMMENTS
2	DOCUMENTATION							
2.1	Material Safety Data Sheets					Clear, Legible and in English		
2.2	Batch Test and Inspection Reports					Clear, Legible and in English		
SYMBOLS AND ABBREVIATIONS								
H = HOLD POINT	S = SUPERVISOR							
W = WITNESS POINT	T = TECHNICIAN, EL = ELECTRICIAN	REVISION						
V = VERIFICATION POINT	E = ENGINEER	DATE						
S/C = SUBCONTRACTOR	PM = PROJECT MANAGER	APPROVED BY						

**APPENDIX C SCHEDULES A & B**

	<b>SPECIFICATION ENQUIRY</b>	HPC-8MJ-07-0002-2018
	<b>VENDOR'S NAME</b>	
	<b>DATE</b>	

**TECHNICAL SCHEDULES  
ITEMS: MV Composite Cross-arms**

<b>Arrangement</b>	Intermediate	Strain / Termination
	1.1	1.2

**SCHEDULE A : Horizon Power's specific requirements**

**SCHEDULE B: Particulars to be completed by Vendor for each ITEM offered**

Clause	Description	Schedule A	Schedule B
3.1	<b>General</b> Manufacturer Brand / Catalogue No. / Model Country of Manufacture		
3.2	<b>Dimensions</b>		
3.2	Width (mm)		
3.2	Height (mm)		
3.2	Length (mm)		
3.3	<b>Particulars of Cross-arm</b> Loading points and End caps		
3.4	Design life (years)	≥ 50	
3.5.1	Application Loads		
3.5.2	Serviceability (%)	≤ 5%	
3.6	Electrical Properties		
3.7	Durability		
3.8	Maintenance		
3.9	Environmental Parameters		
3.10	Cross-arm Coating		
3.11	Compatibility and Interchangeability		
3.12	Weight		
5	Storage		

PROTECTED

**APPENDIX D COMPLIANCE DOCUMENT**

The Vendor shall indicate below whether this offer is fully compliant with the nominated clause in this Specification. A YES shall ONLY be indicated if the offer is 100% compliant with the relevant clause. If NO is indicated and supporting documents are submitted, then mark the ATT box with the attachment number.

CLAUSE NUMBER		YES	NO	ATT.
3	REQUIREMENTS			
3.1	General	<input type="checkbox"/>	<input type="checkbox"/>	<input type="checkbox"/>
3.2	Dimensions	<input type="checkbox"/>	<input type="checkbox"/>	<input type="checkbox"/>
3.3	Loading Points & End Caps	<input type="checkbox"/>	<input type="checkbox"/>	<input type="checkbox"/>
3.4	Design Life	<input type="checkbox"/>	<input type="checkbox"/>	<input type="checkbox"/>
3.5	Strength			
3.5.1	<i>Applicable Loads</i>	<input type="checkbox"/>	<input type="checkbox"/>	<input type="checkbox"/>
3.5.2	<i>Serviceability</i>	<input type="checkbox"/>	<input type="checkbox"/>	<input type="checkbox"/>
3.6	Electrical Properties	<input type="checkbox"/>	<input type="checkbox"/>	<input type="checkbox"/>
3.7	Durability	<input type="checkbox"/>	<input type="checkbox"/>	<input type="checkbox"/>
3.8	Maintenance	<input type="checkbox"/>	<input type="checkbox"/>	<input type="checkbox"/>
3.9	Environmental Parameters	<input type="checkbox"/>	<input type="checkbox"/>	<input type="checkbox"/>
3.10	Cross-arm Coating	<input type="checkbox"/>	<input type="checkbox"/>	<input type="checkbox"/>
3.11	Compatibility and Interchangeability	<input type="checkbox"/>	<input type="checkbox"/>	<input type="checkbox"/>
3.12	Weight	<input type="checkbox"/>	<input type="checkbox"/>	<input type="checkbox"/>
4	PACKAGING REQUIREMENTS	<input type="checkbox"/>	<input type="checkbox"/>	<input type="checkbox"/>
5	STORAGE	<input type="checkbox"/>	<input type="checkbox"/>	<input type="checkbox"/>
6	RELIABILITY	<input type="checkbox"/>	<input type="checkbox"/>	<input type="checkbox"/>
7	SAFETY	<input type="checkbox"/>	<input type="checkbox"/>	<input type="checkbox"/>
8	ENVIRONMENTAL CONSIDERATIONS	<input type="checkbox"/>	<input type="checkbox"/>	<input type="checkbox"/>
9	TESTS			

PROTECTED

9.1	Test Requirements	<input type="checkbox"/>	<input type="checkbox"/>	<input type="checkbox"/>
9.2	Test Certificates	<input type="checkbox"/>	<input type="checkbox"/>	<input type="checkbox"/>
9.3	Mechanical Tests	<input type="checkbox"/>	<input type="checkbox"/>	<input type="checkbox"/>
9.4	Electrical Tests	<input type="checkbox"/>	<input type="checkbox"/>	<input type="checkbox"/>
9.4.1	<i>Tracking and Erosion Test</i>	<input type="checkbox"/>	<input type="checkbox"/>	<input type="checkbox"/>
9.5	Durability Tests			
9.5.1	<i>Aging (UV with Moisture)</i>	<input type="checkbox"/>	<input type="checkbox"/>	<input type="checkbox"/>
9.5.2	<i>Rainfall and High Humidity</i>	<input type="checkbox"/>	<input type="checkbox"/>	<input type="checkbox"/>
9.5.3	<i>Resistance to Fire Damage</i>	<input type="checkbox"/>	<input type="checkbox"/>	<input type="checkbox"/>
9.5.4	<i>Pollution</i>	<input type="checkbox"/>	<input type="checkbox"/>	<input type="checkbox"/>
9.6	Batch Tests	<input type="checkbox"/>	<input type="checkbox"/>	<input type="checkbox"/>
10	DOCUMENTS AND SAMPLES			
10.1	Documentation to be Provided with Proposals	<input type="checkbox"/>	<input type="checkbox"/>	<input type="checkbox"/>
10.2	Service History	<input type="checkbox"/>	<input type="checkbox"/>	<input type="checkbox"/>
10.3	Training Materials	<input type="checkbox"/>	<input type="checkbox"/>	<input type="checkbox"/>
10.4	Samples	<input type="checkbox"/>	<input type="checkbox"/>	<input type="checkbox"/>



APPENDIX F INDICATIVE DRAWING OF THE COMPOSITE CROSS-ARM

Cross-arm 3300 mm

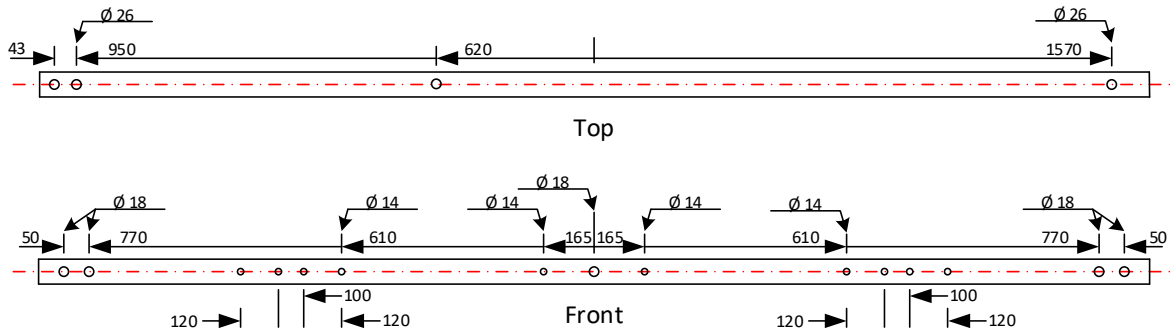

Cross-arm 2400 mm

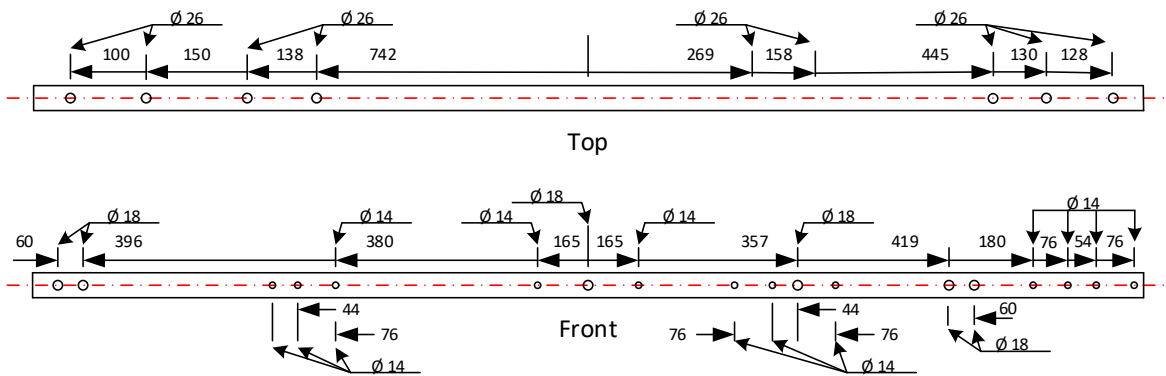

APPENDIX G INTERMEDIATE INSULATOR PIN

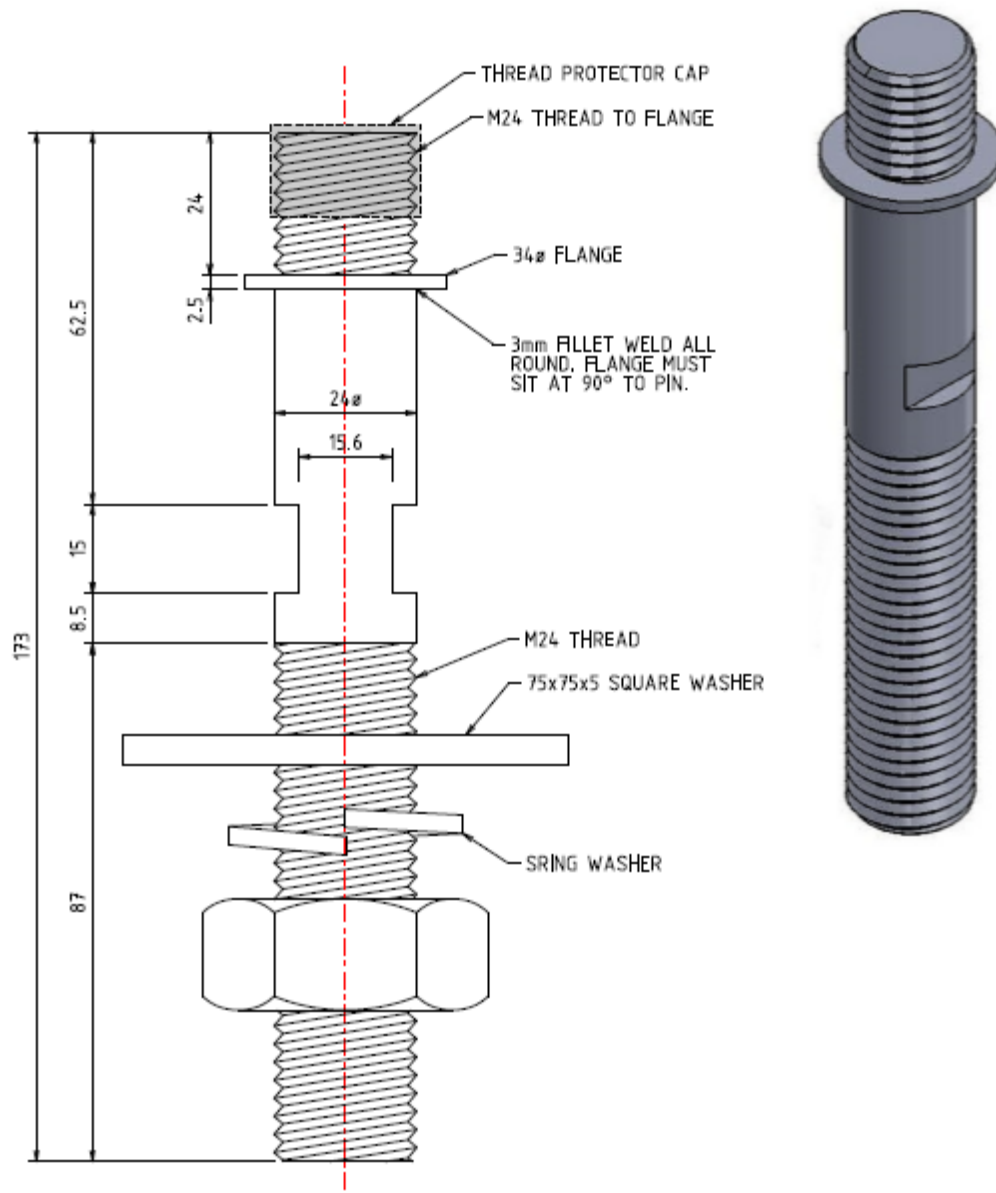

NOTES:

1. ALL DIMENSIONS ARE IN MILLIMETRES.
2. STEEL MATERIAL SHOULD BE GRADE 4.6 OR EQUIVALENT.
3. AFTER FABRICATION ALL BURRS AND SHARP EDGES TO BE REMOVED.
4. MATERIAL TO BE HOT DIP GALVANISED AS PER AS/NZS 4680 OR EQUIVALENT.
5. CONICAL SPRING WASHER TO BE GALV. SPRING STEEL (RANGE 2) TO AS/NZS 1472 OR EQUIVALENT.

STOCK CODE: AB4822

PROTECTED

**APPENDIX H STRAIN/TERMINATION INSULATOR EYE-BOLT**

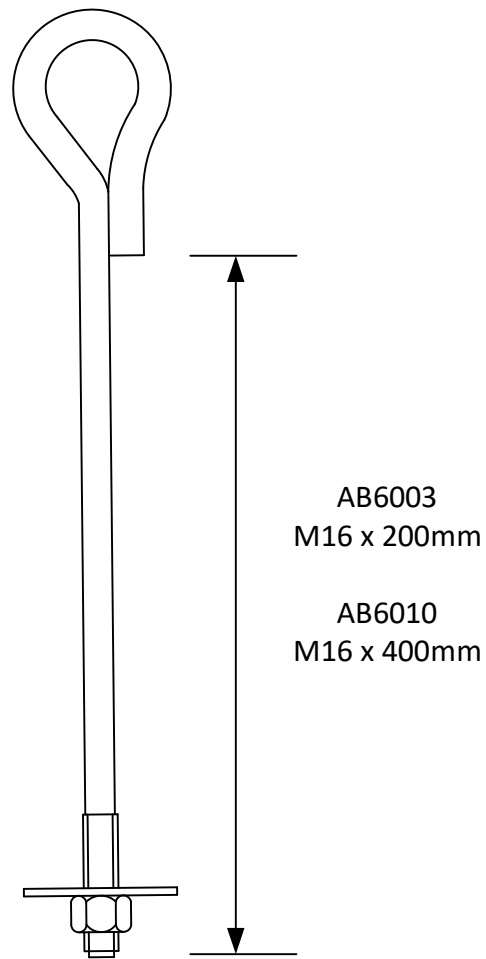



APPENDIX I 'T' BRACKET

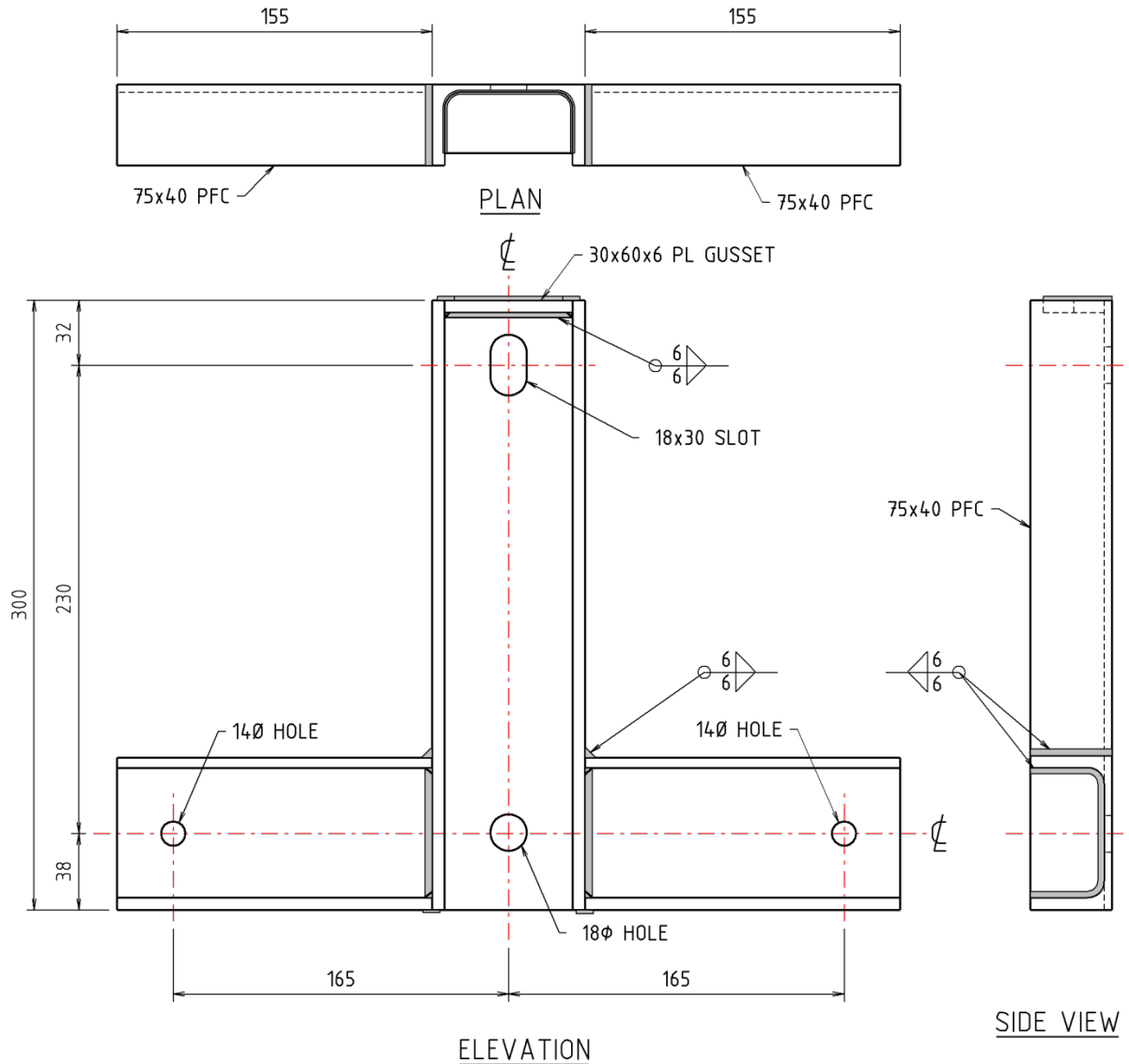

NOTES:-

1. ALL DIMENSIONS ARE IN MILLIMETRES.
2. NO FABRICATED ELEMENT OR COMPONENT IS TO BE FABRICATED FROM SHORT-PIECES.
3. WELDS TO BE 6mm FILLET (STRENGTH NOT LESS THAN 0.733kN/mm) AND TO BE AS PER AS/NZS 1554.1 TO GP STANDARD UNO.
4. WELD SYMBOLS SHOWN ARE TO AS 1101.3.
5. MATERIALS TO BE HOT DIP GALVANISED AS PER AS/NZS 4680D OR EQUIVALENT.
6. STEEL HOT ROLLED SECTIONS TO COMPLY WITH AS/NZS 3679.1 OR EQUIVALENT.
7. SS REFER TO STAINLESS STEEL Gr304.

STOCK CODE: CB3025

APPENDIX J 'RAISER' BRACKETS

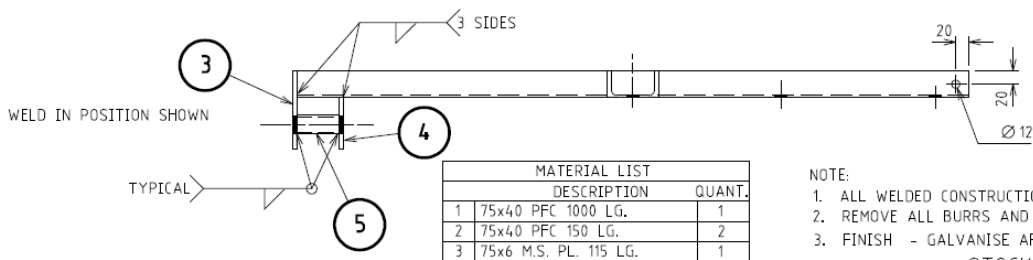
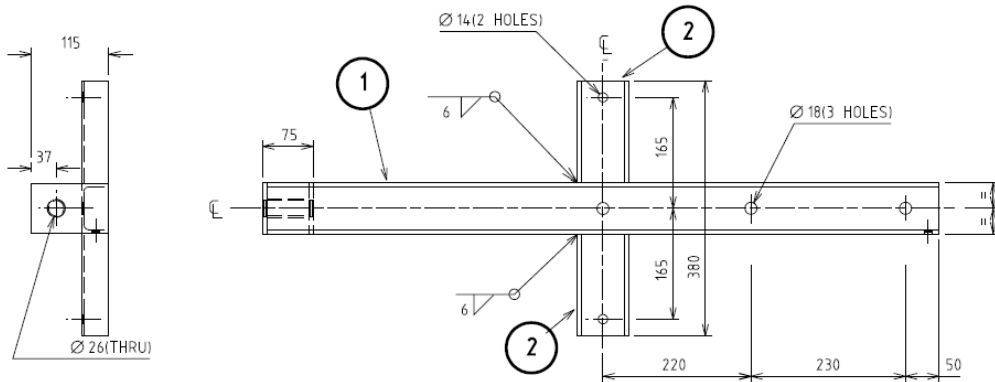

MATERIAL LIST	
DESCRIPTION	QUANT.
1 75x40 PFC 1000 LG.	1
2 75x40 PFC 150 LG.	2
3 75x6 M.S. PL. 115 LG.	1
4 75x6 M.S. PL. 75 LG.	1
5 25 NB MED PIPE 63 LG.	1

NOTE:  
 1. ALL WELDED CONSTRUCTION.  
 2. REMOVE ALL BURRS AND SHARP EDGES.  
 3. FINISH - GALVANISE AFTER FABRICATION

STOCK No. CR1038  
 P/N 0025

MATERIAL LIST	
DESCRIPTION	QUANT.
1 75x40 PFC 635 LG.	1
2 75x40 PFC 150 LG.	2
3 75x6 M.S. PL. 115 LG.	1
4 75x6 M.S. PL. 75 LG.	1
5 25 NB MED PIPE 63 LG.	1

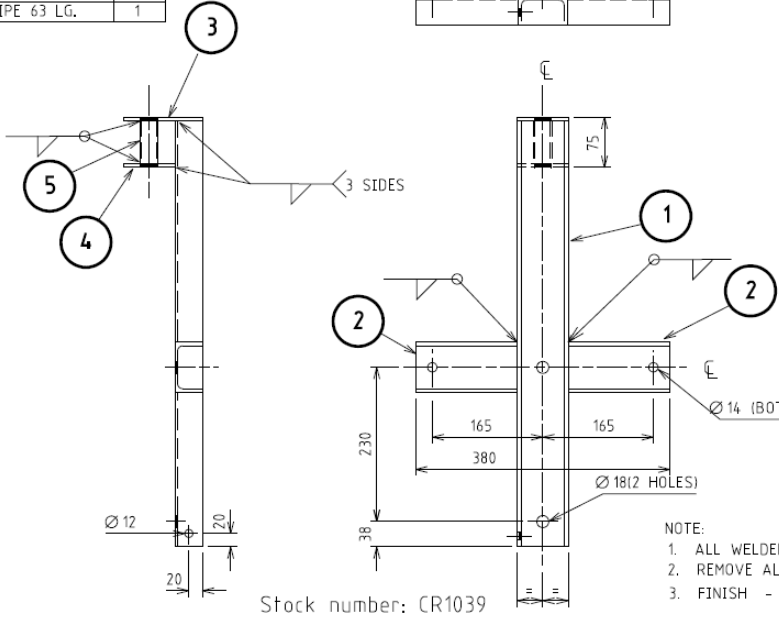
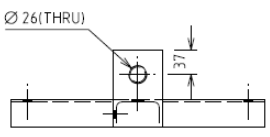

NOTE:  
 1. ALL WELDED CONSTRUCTION.  
 2. REMOVE ALL BURRS AND SHARP EDGES.  
 3. FINISH - GALVANISE AFTER FABRICATION

Stock number: CR1039  
 P/N 0067

'E'	Drawn	JS M
	Checked	
	Date	7/03
HEAD MODIFIED MATERIAL LIST ADDED.		
'D'	Drawn	RJP
	Checked	
	Date	4/98
DIM 100 WAS 100 DIM 38 WAS 48 PUMP PIPE ADDED. PLATES POSITION REVISED.		